









- 

Integrierte Absturz- und Auflaufsicherung
Integrated derailment and bumping protection
Avec anti-chute et anti-basculement
- 

Verzinkter Lastbolzen, Einstellscheiben und Befestigungsmuttern
Zinc plated load bars, washers and locking nuts
Traverses, entretoises et bagues zinguées
- 

Festigkeitsberechnung nach DIN 15018
According to DIN 15018
Calculé suivant DIN 15018
- 

Laufrollenprofil passend für alle Normträger
Adjustable to all standard beam sizes
Adaptable sur tous profils de roulement standard
- 

Kugelgelagerte Laufrollen
Trolley wheels with ball bearing
Galets avec roulement à billes
- 

Deutsche Herstellung
Manufactured in Germany
Fabrication Européenne

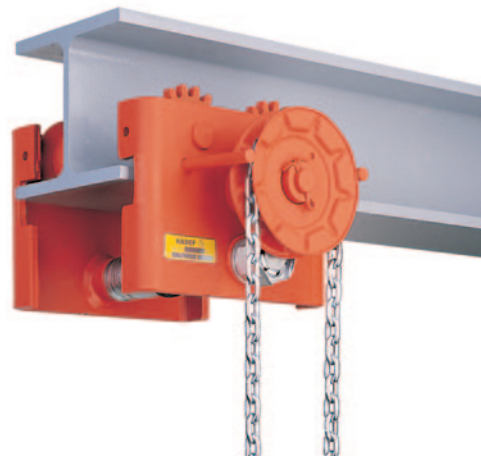

Tragfähigkeit Capacity Capacité	Flanschbreite von - bis bei Lastbolzengröße Flange width from - to for load bar size Largeur de fer de - à pour traverse		Fahrweg bei Abhaspelung von 30 m Handkette travel distance at 30 m hand chain path translation par déroulement de 30 m de chaîne de manoeuvre	Handkraft bei Nennlast hand chain pull effort à la chaîne de manoeuvre	Gewicht Weight Poids	
	1N	2N			1N	2N
	kg	mm			mm	ca. daN approx. daN env. daN
500	50 - 146	147 - 302	7,8	6,5	6,3	7,8
1000	50 - 179	180 - 310	10,0	10,0	12,2	15,1
1500	50 - 173	174 - 316	10,0	15,0	17	20,7
2000	50 - 173	174 - 316	10,0	20,0	17	20,5
2500	66 - 186	187 - 310	6,5	12,0	32,1	34,5
3200	66 - 186	187 - 310	6,5	16,0	32,1	34,5
5000	74 - 182	183 - 310	6,3	17,0	56,7	61,5
6300	74 - 164	165 - 310	6,3	21,0	56,7	61,5
7500	119 - 189	190 - 310	6,4	21,0	104,0	116,6
10000	119 - 160	161 - 310	3,2	14,0	104,0	116,6
12500	130 - 310	-	4,8	17,0	241,0	-
16000	130 - 310	-	4,8	21,0	241,0	-
20000	160 - 310	-	3,7	17,0	297,4	-
25000	160 - 310	-	3,7	17,0	381,1	-

Größere Tragfähigkeiten auf Anfrage. / Larger capacities on request. / Capacités plus grandes sur demande



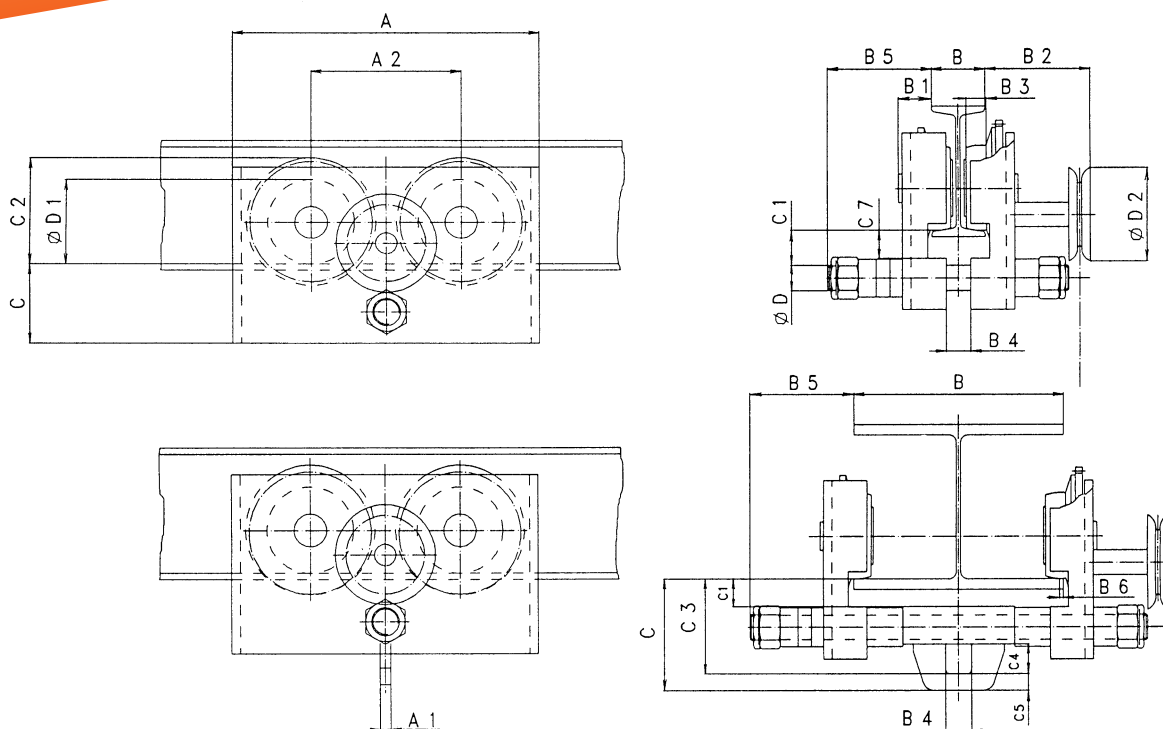

Trag- fähigkeit capacity capacité kg	Flanschbreite B von/ bis flange width B from/ to largeur de fer B de - à mm	Last- bolzen load bar traverse Größe size taille	Hauptabmessungen in mm main dimensions in mm dimensions principales en mm																					
			A	A 1	A 2	B 1	B 2	B 3	B 4	B 5	B 6	C	C 1	C 2	C 3	C 4	C 5	C 7	D	D 1	D 2			
			500	50 - 146 147 - 302	1 N 2 N	165	- 10	75	24	99	20	26	127 157	7	75 113	46 39	59	- 96	- 28	- 17	28	18	50	135
			1000	50 - 179 180 - 310	1 N 2 N	232	- 12	110	31	116	20	32	156	7	118 151	69 56	83	134	33	17	40	24	65	135
1500	50 - 173 174 - 316	1 N 2 N	240	- 12	110	33	112	20	36	171	7	118 166	65 54	83	144	40	22	38	30	65	135			
2000	50 - 173 174 - 316	1 N 2 N	240	- 12	110	35	121	20	36	171	7	118 166	65 54	83	144	40	22	38	30	65	135			
2500	66 - 186 187 - 310	1 N 2 N	315	- 15	148	44	146	23	46	179 182	10	134 200	76 63	107	170	52	30	43	36	83	195			
3200	66 - 186 187 - 310	1 N 2 N	315	- 15	148	44	146	23	46	179 182	10	134 200	76 63	107	170	52	30	43	36	83	195			
5000	74 - 182 183 - 310	1 N 2 N	435	- 20	211	53	145	28	52	183 197	13	150 229	85 73	151	194	62	35	40	39	120	195			
6300	74 - 164 165 - 310	1 N 2 N	435	- 20	211	53	145	28	52	183 197	13	150 229	85 73	151	194	62	35	40	39	120	195			
7500	119 - 189 190 - 310	1 N 2 N	494	- 30	230	69	250	40	74	213 241	15	220 323	136 115	186	- 278	- 80	- 45	45	48	150	270			
10000	119 - 160 161 - 310	1 N 2 N	494	- 30	230	69	250	40	74	231 241	15	220 323	136 115	186	278	80	45	45	48	150	270			
12500	130 - 310	1 N	630	-	286	91	318	45	84	210	15	246	128	267	-	-	-	50	75	200	365			
16000	130 - 310	1 N	630	-	286	91	318	45	84	194	15	246	128	267	-	-	-	50	75	200	365			
20000	160 - 310	1 N	736	-	350	95	321	55	100	199	20	280	150	292 ⁽¹⁾	-	-	-	45	80	250	555			
25000	160 - 310	1 N	834	-	400	97	298	60	106	135	20	318	180	347	-	-	-	50	85	300	555			

⁽¹⁾ bis Oberkante Handkettenrad 313 mm/ up to upper edge of hand chain wheel 313 mm/ jusqu'à la partie supérieure du volant de manoeuvre 313 mm





22/90

Einschienen-Haspelfahrwerk/ Monorail Hand Geared Trolley/
Chariot à avance par chaîne

ISO 9001
certified company

PREMIUM LINE

+ Optionen/ Options / Options

Feststellvorrichtung
Beam locking device
Dispositif de blocage sur fer

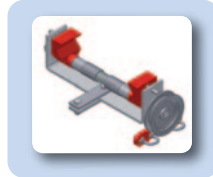

Gummipuffer
Rubber end stops
Butées caoutchouc

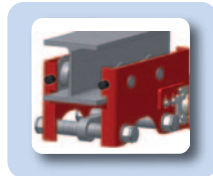

Zahnstangenantrieb
Rack and pinion drive
Entraînement sur crémaillère

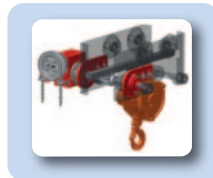

Drehschemelfahrwerk für sehr
kleine Kurvenradien
Swivelling trolley for very small
curve radius
Boogie pour radius de courbe
plus petite



Komplett verzinkte Ausführung
Totally zinc plated trolley
Réalisation entièrement zinguée

