



Votre distributeur  
et réparateur  
T. 01 76 21 07 46  
www.tlm77.com



# HADEF

## 67/19 AT

Ausgleichs- und Traversiergerät/ Load Balancer and Traversing Device/  
Appareil de compensation de la charge et appareil à chaîne traversante

ISO 9001  
certified company

PREMIUM LINE

NEU · NEW  
NOUVEAU



Die Innovation für Ihre  
Sicherheit von HADEF

Innovation for your safety  
designed by HADEF

Innovation HADEF pour  
votre sécurité

67/19 AT

ISO 9001  
certified company

Ausgleichs- und Traversiergerät /Load Balancer and Traversing Device/  
Appareil de compensation de la charge et appareil à chaîne traversante

PREMIUM LINE



**HADEF**



- ✓ Industriesteckverbindung für Stromanschluss und Steuerschalter  
[Plug-in connection for power supply and pendant control](#)  
Connecteur pour raccordement au réseau électrique et boîtier de commande
- ✓ Schützsteuerung 48 V  
[Contactor control 48 V](#)  
Commande basse tension 48 V
- ✓ Phasenüberwachungsrelais  
[Phase monitoring relay](#)  
Relais d'inversion de phases
- ✓ Thermofühler im Hubmotor  
[Thermo sensor in the hoist motor](#)  
Sonde thermique pour moteur de levage
- ✓ Betriebsstundenzähler  
[Operating hours counter](#)  
Compteur horaire
- ✓ Überlastsicherung durch Rutschkupplung und Stromabschaltung (AK 4 – 8)  
[Overload protection by slipping clutch and current cut-off \(AK 4 -8\)](#)  
Limiteur de charge à friction et électrique (AK 4 – 8)
- ✓ Überlastsicherung durch Stromabschaltung (AT 9 – 10)  
[Overload protection by current cut-off \(AT 9 – 10\)](#)  
Limiteur de charge électrique (AT 9-10)
- ✓ Getriebeendschalter für die Endlagenabschaltung  
[Gear limit switch for end position actuation](#)  
Limiteur de course pour arrêt haut et bas
- ✓ HADEF Anstrich C2 – Farbton RAL 1006  
[HADEF paint C2 – color RAL 1006](#)  
Peinture HADEF C2 – couleur RAL 1006
- ✓ Schutzart IP 55, optional IP 66 (geschützt gegen Staub und Überflutung)  
[IP 55 enclosure, IP 66 as option \(protection against particles and water\)](#)  
Indice de protection IP55, IP 66 optionnellement (protection contre les poussières et contre les forts jets d'eau)



# HADEF

## 67/19 AT

Ausgleichs- und Traversiergerät/ Load Balancer and Traversing Device/  
Appareil de compensation de la charge et appareil à chaîne traversante

ISO 9001  
certified company

PREMIUM LINE

**Vielfältige Anwendungsmöglichkeiten**  
**Variety of applications**  
**Diversité des applications**

Gerät mit 2 Haken  
**two hooks**  
deux crochets

exakt positionieren  
in jede Richtung  
**precise positioning**  
**in any position**  
placement exact  
dans toutes les positions

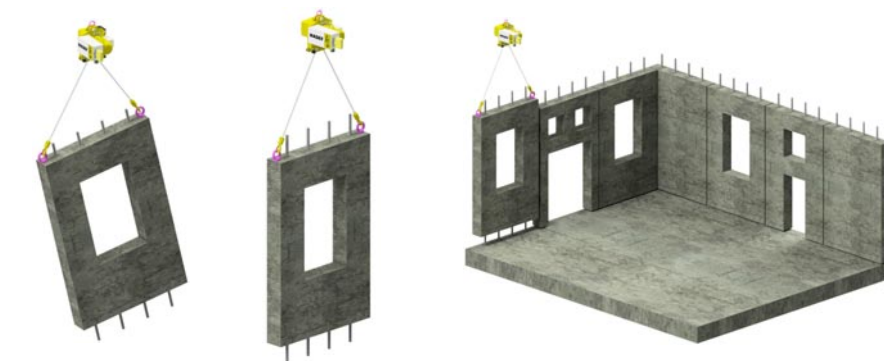
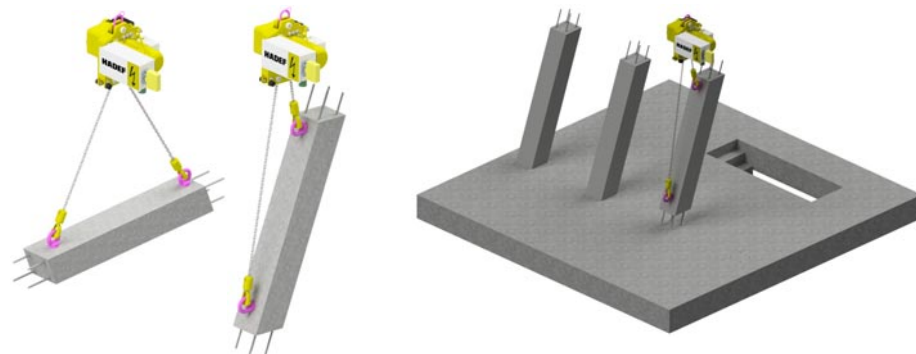

Video

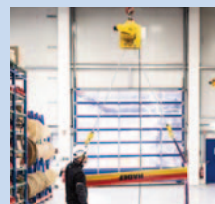
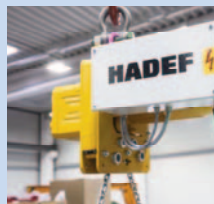
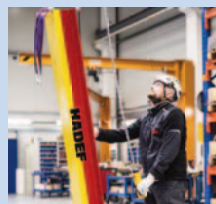
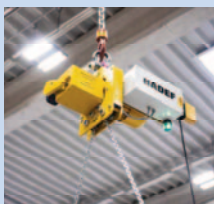

[hadeff.de/  
video-hadef-67-19-AT.html](http://hadeff.de/video-hadef-67-19-AT.html)



[hadeff.com/  
video-hadef-67-19-AT.html](http://hadeff.com/video-hadef-67-19-AT.html)



[hadeff.fr/  
video-hadef-67-19-AT.html](http://hadeff.fr/video-hadef-67-19-AT.html)



| [hadeff.com](http://hadeff.com) |

# HADEF

# 67/19 AT

ISO 9001  
certified company

Ausgleichs- und Traversiergerät /Load Balancer and Traversing Device/  
Appareil de compensation de la charge et appareil à chaîne traversante

PREMIUM LINE



# HADEF



Lastverteilung symmetrisch  
Symmetric load distribution  
Répartition symétrique  
de la charge

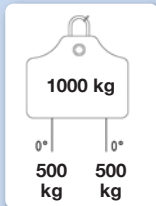

Lastverteilung asymmetrisch  
Asymmetric load distribution  
Répartition asymétrique  
de la charge

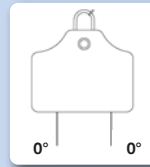
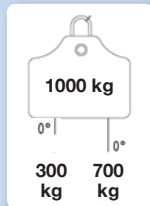

Ablenkwinkel der Last  
Deflection angle  
Angle de dérivation

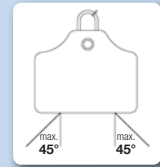

Modell Type Type	symmetrisch/ symmetric/ symétrique		asymmetrisch/ asymmetric/ asymétrique		Maße Aufhängering Suspension ring Oeillet de suspension mm	Verstell- geschwindig- keit Adjustment speed Vitesse d'ajustement m/min	Ketten- abmessung Chain dimension Dimension de chaîne mm	Nutzlänge je Strang Available length per chain fall Chaîne disponible par brin m	Kettenlänge gesamt Total chain length Longueur totale de chaîne m	Gewicht Weight Poids	
	Tragfähigkeit Capacity Capacité		Tragfähigkeit Capacity Capacité							kg	+ 1 m Hub/ lift/ levée kg
	Ablenkwinkel der Last Deflection angle Angle de dérivation		Ablenkwinkel der Last Deflection angle Angle de dérivation								
	0°	max. 45°	0°	max. 45°							
AT 4	500 (250 / 250)	500 (250 / 250)	500 (10 / 490)	500 (150 / 350)	13 x 60 x 110	9,4/2,6	5 x 15	2	4,4	105	1,2
AT 6	1000 (500 / 500)	1000 (500 / 500)	1000 (10 / 990)	1000 (300 / 700)	16 x 60 x 110	8,0/2,0	7 x 21	2	4,5	205	2,2
AT 8	2000 (1000 / 1000)	2000 (1000 / 1000)	2000 (10 / 1990)	2000 (600 / 1400)	18 x 75 x 135	10,0/2,5	11,3 x 31	3	6,9	330	5,8
AT 9	5000 (2500 / 2500)	5000 (2500 / 2500)	5000 (10 / 4990)	5000 (1500 / 3500)	22 x 90 x 160	5,4/1,35	16 x 45	3	7,3	425	11,4
AT 10	10000 (5000 / 5000)	10000 (5000 / 5000)	10000 (10 / 9990)	10000 (3000 / 7000)	36 x 140 x 260	5,8/1,4	23,5 x 66	5	11,8	1020	24,4



# HADEF

## 67/19 AT

Ausgleichs- und Traversiergerät/ Load Balancer and Traversing Device/  
Appareil de compensation de la charge et appareil à chaîne traversante

ISO 9001  
certified company

PREMIUM LINE

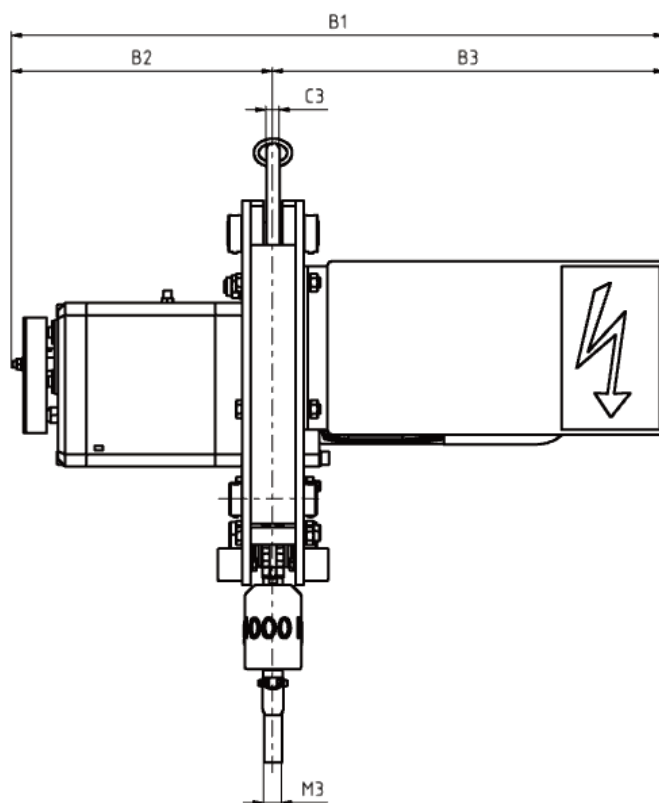
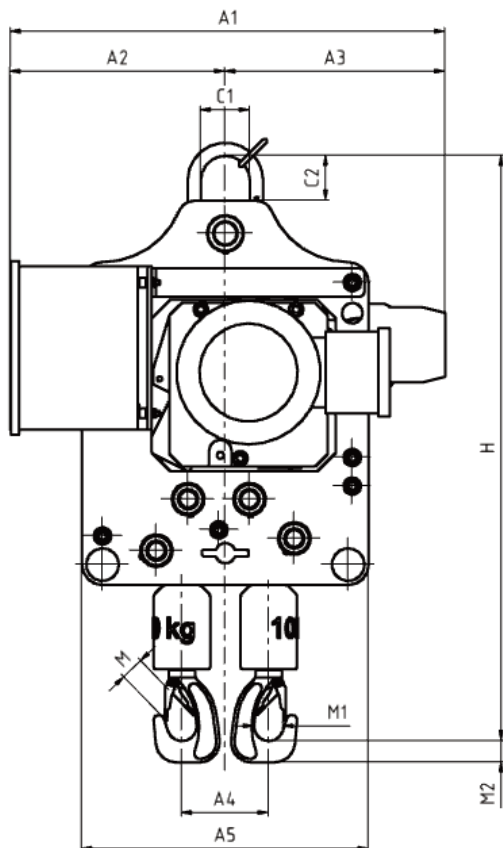

Modell	Maße Aufhängering	Hauptabmessungen in mm															
		A1 <sup>(1)</sup>	A2 <sup>(1)</sup>	A3	A4	A5	B1 <sup>(1)</sup>	B2 <sup>(1)</sup>	B3 <sup>(1)</sup>	C1	C2	C3	M	M1	M2	M3	H
AT 4	13 x 60 x 110	526	310	215	80	265	601 (695)	287 (345)	314	60	60	13	25	30	18	17	606
AT 6	16 x 60 x 110	532	262	269	106	350	879 (936)	319	560 (617)	60	55	16	29	36	26	22	716
AT 8	18 x 75 x 135	524	237	287	152	400	843	357	486	75	78	18	32	50	40	38	829
AT 9	22 x 90 x 160	650 (707)	338 (395)	312	146	460	776	287	489	90	95	22	32	50	40	38	1027
AT 10	36 x 140 x 260	700 (745)	350 (395)	350	214	700	1176	424	752	140	185	36	40	63	58	53	1569

(1) Maße in Klammern bei Funkfernsteuerung/ Dimensions in brackets for radio control/ Dimensions entre parenthèses pour radio commande

67/19 AT

ISO 9001  
certified company

Ausgleichs- und Traversiergerät/ Load Balancer and Traversing Device/  
Appareil de compensation de la charge et appareil à chaîne traversante



**HADEF**

PREMIUM LINE



## Optionen/ Options / Options

Andere Spannung  
Other voltages  
Autres tensions



Funksteuerung  
Radio control  
Radio commande à distance



Frequenzsteuerung  
Frequency control  
Variateur de fréquence



Sonderanstriche  
Special paint  
Peintures spéciales



Edelstahl-Schaltkasten  
Stainless steel terminal box  
Armoire de commande inox



Transport- und Ablagewagen  
Transport and storage trolley  
Chariot de transport

